

Guidelines on the Calibration of Electromechanical Manometers

EURAMET cg-17

Version 2.0 (03/2011)

Previously EA-10/17



Calibration Guide

Calibration Guide

EURAMET cg-17

Version 2.0 (03/2011)



GUIDELINES ON THE CALIBRATION OF ELECTROMECHANICAL MANOMETERS

Purpose

This document has been produced to enhance the equivalence and mutual recognition of calibration results obtained by laboratories performing calibrations of electromechanical manometers.

Authorship and Imprint

This document was developed by the EURAMET e.V., Technical Committee for Mass and Related Quantities.

2nd version March 2011

1st version July 2007

EURAMET e.V.
Bundesallee 100
D-38116 Braunschweig
Germany

e-mail: secretariat@euramet.org

phone: +49 531 592 1960

Official language

The English language version of this document is the definitive version. The EURAMET Secretariat can give permission to translate this text into other languages, subject to certain conditions available on application. In case of any inconsistency between the terms of the translation and the terms of this document, this document shall prevail.

Copyright

The copyright of this document (EURAMET cg-17, version 2.0 – English version) is held by © EURAMET e.V. 2010. The text may not be copied for sale and may not be reproduced other than in full. Extracts may be taken only with the permission of the EURAMET Secretariat.

ISBN 978-3-942992-14-5

Guidance Publications

This document gives guidance on measurement practices in the specified fields of measurements. By applying the recommendations presented in this document laboratories can produce calibration results that can be recognized and accepted throughout Europe. The approaches taken are not mandatory and are for the guidance of calibration laboratories. The document has been produced as a means of promoting a consistent approach to good measurement practice leading to and supporting laboratory accreditation.

The guide may be used by third parties e.g. National Accreditation Bodies, peer reviewers witnesses to measurements etc., as a reference only. Should the guide be adopted as part of a requirement of any such party, this shall be for that application only and EURAMET secretariat should be informed of any such adoption.

On request EURAMET may involve third parties in a stakeholder consultations when a review of the guide is planned. Please register for this purpose at the EURAMET Secretariat.

No representation is made nor warranty given that this document or the information contained in it will be suitable for any particular purpose. In no event shall EURAMET, the authors or anyone else involved in the creation of the document be liable for any damages whatsoever arising out of the use of the information contained herein. The parties using the guide shall indemnify EURAMET accordingly.

Further information

For further information about this document, please contact your national contact person of the EURAMET Technical Committee for Mass and Related Quantities (see www.euramet.org).

Calibration Guide

EURAMET cg-17

Version 2.0 (03/2011)



GUIDELINES ON THE CALIBRATION OF ELECTROMECHANICAL MANOMETERS

Contents

1	INTRODUCTION.....	1
2	REFERENCE DOCUMENTS AND LITERATURE	1
3	Definitions	2
4	PRINCIPLES OF THE ELECTROMECHANICAL MANOMETERS.....	2
	4.1 Pressure transducers	2
	4.2 Pressure transmitters	2
	4.3 Manometers with digital or analogue indication	2
5	Laboratory calibration procedures	3
	5.1 Installation of the equipment	3
	5.2 Methods of calibration	3
	5.3 Means to be used	4
	5.4 Calibration sequences	8
6	DETERMINATION OF THE UNCERTAINTY OF MEASUREMENT	12
	6.1 Common aspects of determining the uncertainty of measurement	12
	6.2 Guidance on uncertainty calculation for selected practical cases	15
7	EXAMPLES.....	21
	7.1 Example 1 - Calibration of an indicating digital pressure gauge	21
	7.2 Example 2 - Calibration of a pressure transducer	24

Calibration Guide

EURAMET cg-17

Version 2.0 (03/2011)



Guidelines on the Calibration of Electromechanical Manometers

1 INTRODUCTION

This document deals with the calibration of electromechanical manometers. The document does not cover dial gauges as there are standards for this type of instrument.

The Guidelines provide the users of electromechanical manometers with the fundamentals necessary for establishing and applying calibration procedures.

These Guidelines apply to all electromechanical manometers for measuring absolute, gauge or differential pressures, excluding vacuum devices measuring pressures below 1 kPa.

Notes:

- a The Guidelines refer to the "measurement" function of a measuring pressure controller in particular.
- b The Guidelines do not refer to piezoelectric pressure transducers.

2 REFERENCE DOCUMENTS AND LITERATURE

VIM, International vocabulary of basic and general terms in metrology, issued by BIPM, IEC, IFCC, ISO, IUPAC, IUPAP and OIML, 1993

GUM, Guide to the expression of uncertainty in measurements, issued by BIPM, IEC, IFCC, ISO, IUPAC, IUPAP and OIML, 1993 (revised in 1995)

EA-4/02 (rev 00), Expression of the uncertainty of measurement in calibration, 1999

EA-4/07 (rev 01), Traceability of measuring and test equipment to national standards, 1995

RM Aero 802 41, Calibration and check of electromechanical manometers, Bureau de Normalisation de l'Aéronautique et de l'Espace, BNAE, 1993 (*in French*)

IEC 60770, Transmitters for use in industrial-process control; Part1: Methods for performance evaluation, 1999; Part 2: Guidance for inspection and routine testing, 1989

3 Definitions

In order to avoid ambiguity, the terms mentioned below have the following meanings:

Line pressure: Static pressure used as a reference for differential pressures.

Reference level: Level at which the value of the applied pressure is quantified.

Note: The manufacturer of the instrument specifies this level. If this is not the case, the calibration laboratory shall specify it.

4 PRINCIPLES OF THE ELECTROMECHANICAL MANOMETERS

The Guidelines deal with three types of electromechanical manometers:

- pressure transducers,
- pressure transmitters,
- manometers with digital or analogue indication.

4.1 Pressure transducers

Pressure transducers convert the measured pressure into an analogue electrical signal that is proportional to the applied pressure.

According to the model, the output signal can be

- a voltage
- a current
- a frequency

To ensure their function, the pressure transducers need a continuous power supply stabilised to a level in relation to the expected uncertainty of the pressure measurement.

4.2 Pressure transmitters

A pressure transmitter generally is a unit that consists of a pressure transducer and a module for conditioning and amplifying the transducer signal.

According to the model, the output information of a pressure transmitter can be:

- a voltage (5 V; 10 V; ...),
- a current (4-20 mA; ...),
- a frequency,
- a digital format (RS 232; ...).

For operation, pressure transmitters need a continuous electrical supply, which need not be specifically stabilised.

4.3 Manometers with digital or analogue indication

This type of manometer is a complete measuring instrument that indicates units of pressure. According to the pattern, it may consist of the following units:

- (a) Manometer with a digital indication:
- pressure transducer,
 - analogue conditioning module,
 - analogue-to-digital converter,

- digital processing module,
 - digital indication (in the unit(s) specified by the manufacturer),
 - electrical power supply unit (generally incorporated).
- (b) Manometer with an analogue indication:
- pressure transducer,
 - analogue conditioning module,
 - analogue indicating module,
 - electrical power supply unit (generally incorporated).

These elements may be accommodated in one housing (internal transducer) or constitute separate devices one of which is the transducer (external transducer).

The manometers may also be equipped with analogue or digital output ports.

Note: Complete calibration of such an instrument makes it necessary to perform a calibration for each output.

5 Laboratory calibration procedures

5.1 Installation of the equipment

- The equipment should be switched on in the calibration laboratory before starting the calibration in order to reach the thermal equilibrium of the whole system.
- Protect the equipment from direct sunlight.
- Clean the instrument.
- Place the instrument to be calibrated as close as possible to the reference standard.
- Ensure that the pressure reference levels of both instruments are as close as possible and account for the difference in the pressure reference level when calculating corrections and uncertainties.
- Respect the manufacturer's specification for mounting position, torque, warm-up, for example.

5.2 Methods of calibration

If appropriate, the procedure of calibration should allow according to the client's requirement the evaluation of the hysteresis, the linearity and the repeatability of the instrument to be calibrated.

The applied procedure depends on the expected accuracy of the instrument according to the client's requirement.

5.2.1 Basic calibration procedure

The basic calibration procedure should be used for instruments where the expected expanded measurement uncertainty ($k=2$) is $U > 0.2\%$ FS. Calibration is performed once at 6 pressure points in increasing and decreasing pressures. Repeatability is estimated from three repeated measurements at one pressure point (preferably 50% FS).

5.2.2 Standard calibration procedure

The Standard calibration procedure should be used for instruments where the expected expanded measurement uncertainty ($k=2$) is $0.05\% \text{ FS} \leq U \leq 0.2\% \text{ FS}$. Calibration is performed once at 11 pressure points in increasing and decreasing pressures.

Repeatability is estimated from calibration at four pressure points (preferably 0, 20, 50, 80% FS) that are repeated three times.

5.2.3 Comprehensive calibration procedure

The Comprehensive calibration procedure should be used for instruments where the expected expanded measurement uncertainty ($k=2$) is $U < 0.05\%$ FS. Calibration is performed at 11 pressure points in three measuring series.

5.3 Equipment set-up

5.3.1 Reference instrument

The reference instrument shall comply with the following requirements

- It shall be traceable to national or international standards.
- Its uncertainty shall be better (if practicable) than that of the instrument to be calibrated, the ratio being in general equal to or greater than 2.

5.3.2 Mechanical set-up

5.3.2.1 Gauge pressure in gaseous media

The typical set-up may be as follows (see figure 1) :

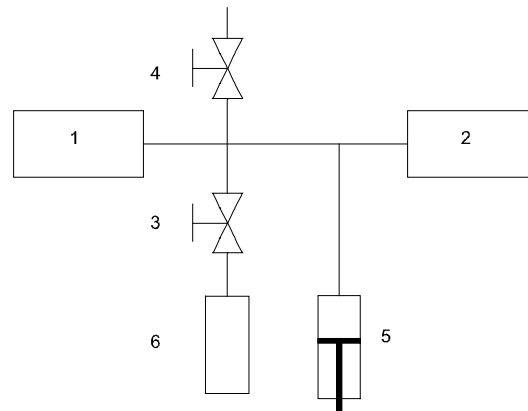

1. reference standard
2. instrument to be calibrated, mounted in a position of its normal use
3. fine-regulated inlet valve
4. fine-regulated pressure relief valve
5. volume regulator
6. pressure source

Figure 1 - Set-up in gauge pressure, gaseous media

It is strongly recommended to use a pressurised container with dry and clean gas as the pressure source. The container must be equipped with a pressure-reducing valve or connected to a pressure control valve if required by the measurement range of the instrument to be calibrated.

The required pressure is roughly set up using inlet or outlet valves depending on whether the pressure is supposed to be set up from low pressure or from high pressure. The final pressure adjustment is performed using a volume regulator.

5.3.2.2 Absolute pressure in gaseous media

The typical set-up may be as follows (see figure 2):

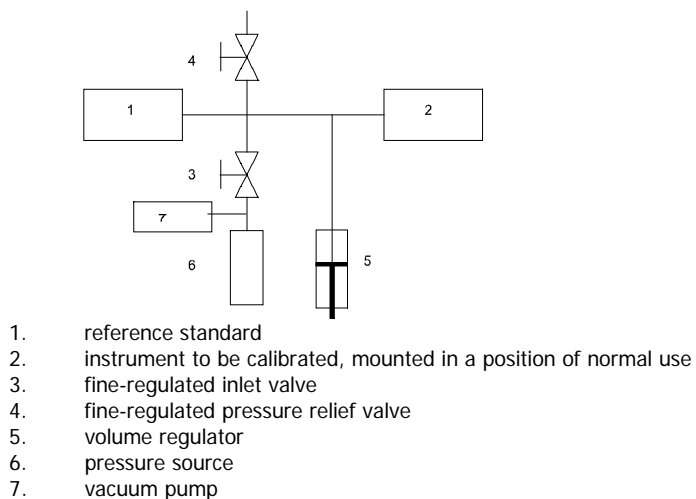

Figure 2 - Set-up in absolute pressure, gaseous media

In order to ensure the quality of the gas, the vacuum pump shall be equipped with accessories such as traps and isolating valves.

In the case of absolute pressures significantly higher than the atmospheric pressure, the use of a gauge pressure reference standard and a barometric pressure-measuring reference standard is acceptable. The set-up recommended for gauge pressures is applicable. The value of the absolute pressure is obtained by summation of the values of the pressures measured with the two reference standards.

5.3.2.3 Gas differential pressure

The following set-up is recommended (see figure 3):

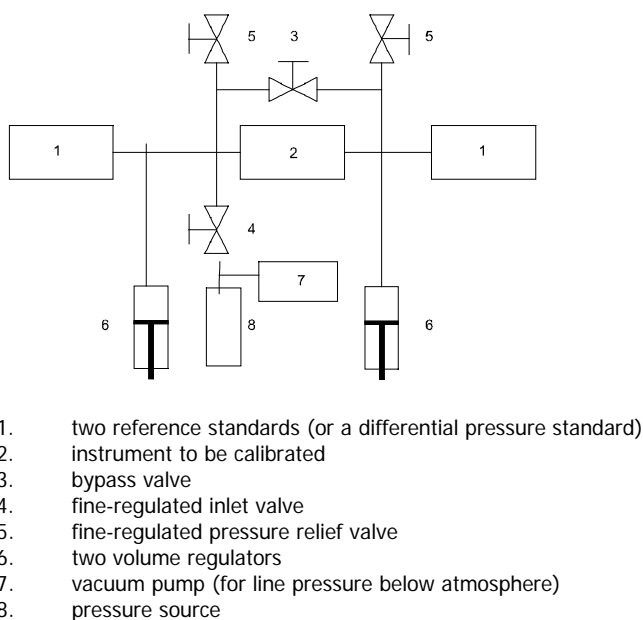

Figure 3 - Set-up in gas differential pressure

The required line pressure is roughly set up using inlet or outlet valves depending on whether the pressure is supposed to be set up from low pressure or from high pressure. The final pressure adjustment is performed using a volume regulator. During this procedure the bypass valve is open.

The required differential pressure is set up using one of the volume regulators.

Instead of using two reference standards, a differential pressure standard or a twin pressure balance may be used.

A vacuum pump arranged downstream of the inlet valve can allow the line pressure to be lower than the atmospheric pressure.

5.3.2.4 Hydraulic pressure

The set-up for gauge pressure and differential pressure is basically the same as that for gaseous media with the following options:

- the relief valves being replaced with discharge valves connected to a reservoir of pressure transmitting fluid,
- the pressure sources being replaced by screw press and/or priming pump.

For absolute liquid pressures, refer to the last paragraph of section 5.3.2.2.

5.3.3 Electrical set-up

This section refers only to transducers and transmitters with an analogue output signal.

If the transducer being calibrated is equipped with a signal conditioner, concerning the electrical set-up follow the manufacturer's instructions

If no signal conditioner is available, a relevant data sheet with manufacturer's specifications shall be available.

If applicable, the voltmeter and the reference standard resistor shall be calibrated and traceable to the corresponding national/international standard.

In every case, it is important to follow the recommendations concerning the electrical shielding, to ensure the quality of the connections (of the "low-level" transducers in particular), to meet the safety requirements. Some instruments may be supplied with a power supply system or are supposed to be connected to such a system.

According to the instrument type, various set-ups are possible. This Guide deals only with the three most typical set-ups:

5.3.3.1 Two-wire transmitters

Generally, this is the case of instruments with DC loop (4 - 20) mA. However some other output signals (0 to 10 mA, 0 to 20 mA or 0 to 50 mA) are applicable.

The typical set-up may be as follows (see figure 4) :

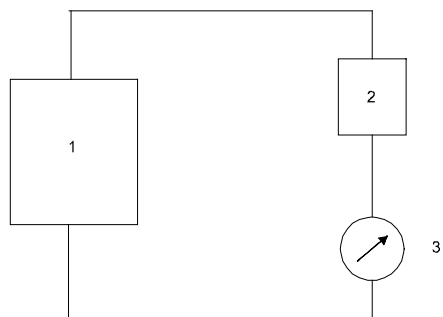

- 1. transmitter
- 2. power supply
- 3. measurement

Figure 4 - Electrical set-up, two-wire transmitters

The current (I) is determined by measuring the output voltage (U_s) at the terminals of a calibrated standard resistor (R):

$$I = U_s / R$$

It is recommended to follow the manufacturer's instructions concerning the values of the power supply voltage and the resistor or the client's specifications when appropriate.

5.3.3.2 Three-wire transmitters or transducers

These are generally instruments with a Wheatstone Bridge. The typical set-up may be as follows (see figure 5):

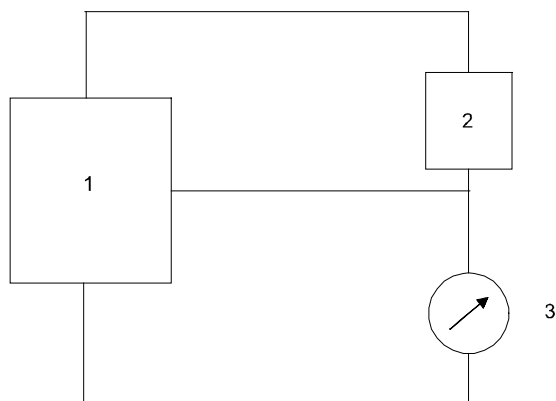

- 1. transmitter or transducer
- 2. power supply
- 3. measurement output

Figure 5 - Electrical set-up, three-wire transmitters or transducers

For the selection of the power supply and the voltage-measuring instrument, it is recommended to follow the manufacturer's specifications. The resistor of this instrument shall, however, be sufficiently high (at least 10 times) compared with the internal resistance of the transmitter or transducer.

5.3.3.3 Four-wire transmitters or transducers

These are generally instruments with a Wheatstone Bridge.

The typical set-up is as follows (see figure 6):

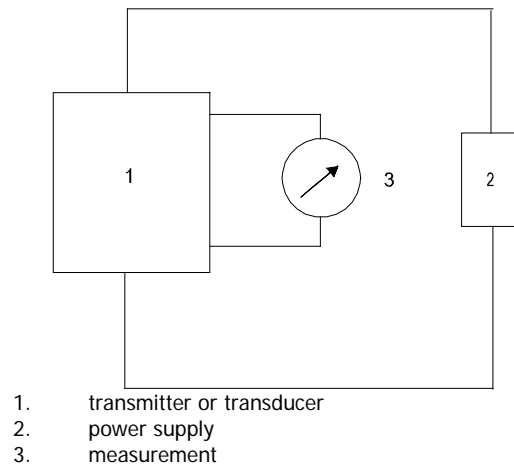

Figure 6 - Electrical set-up, four-wire transmitters or transducers

As the output signal is a low-level signal, it is important to ensure an appropriate quality of the earth connections and of the shielding.

Variants:

- the output signal is an amplified signal from the amplifier (high-level outputs) incorporated in the transmitter.
- some instruments may include a probe for temperature compensation; the output of this probe may consist of one or two supplementary wires.

5.4 Calibration sequences

5.4.1 Preparatory work

Prior to the calibration itself, the good working condition of the instrument shall be visually checked, especially:

- good quality of the electrical contacts,
- cleanliness of the instrument.

It is recommended to perform the following operations:

- identify the reference levels
 - of the reference,
 - of the instrument to be calibrated (at the level of the connection or at the reference level defined by the manufacturer),
- minimise the difference between the reference levels,
- for torque sensitive devices, follows the manufacturer's instructions.

5.4.2 Calibration procedures

In the case of instruments with several outputs, it is sufficient to perform the calibration for the output(s) specified by the user.

Irrespective of the instrument to be calibrated and of the procedure to be used (refer to section 5.2), the operations are performed in three successive steps:

- check of a limited number of pressure points of the measurement range to determine the initial metrological condition of the instrument,
- adjustment of the instrument according to the manufacturer's specification,
- calibration appropriate to the instrument over its whole measurement range or span.

Each of these operations, especially adjustment of the instrument, shall be performed only with the agreement of the client and shall be reported in the calibration certificate.

5.4.2.1 Initial check

To determine the long-term drift of the instrument, it is necessary to provide the user with some information on its condition prior to any potential adjustment.

If the user does not apply for a complete calibration being carried out prior to the adjustment, it is recommended to perform the following operations:

- operate the instrument and bring it at least twice to its upper pressure limit and keep the pressure for at least one minute,
- during the first pressure rise, check out the indication obtained for conformity with the specifications,
- read the indications of the instrument at 0%, 50% and 100% of its measurement span.

5.4.2.2 Adjustment

If the response of the instrument does not conform to the conventional response, i.e. :

- for a digital manometer with direct reading, if there is a difference between the indicated pressure and the applied pressure,
- for a transmitter with electrical output, if there is a deviation from the conventional signal of, for example, 4 to 20 mA),

perform an adjustment of the instrument according to the client's requirements.

Depending on the capabilities of the calibration laboratory such procedure shall be performed:

- with the aid of the means normally accessible to the user (potentiometers for zero and full scale, sometimes with mid-scale),
- with the internal adjustment facilities of the instrument (potentiometers, storage of a calibration curve, etc.), in conformity with the information contained in the technical description, after agreement of the client.

Note: This operation obviously presumes a detailed knowledge of the adjustment procedures and requires specialised operators and calibration means that are more powerful than the instrument to be calibrated.

If the instrument provides scale marks which are useful to the user (calibration notches, restitution of a calibration curve for example), it is recommended to determine these elements in order to report them in the calibration certificate.

5.4.2.3 Main calibration

The calibration procedure to be used (cf. section 5.2) is selected according to the uncertainty of measurement expected for the instrument to be calibrated.

At each calibration point at least the following data shall be recorded:

- the pressure indicated by the reference instrument or the elements necessary for calculating the pressure actually measured (values of masses and temperature for a pressure balance, for example)
- the indication of the instrument to be calibrated.

The following data shall be also recorded:

- the values of the influence quantities (temperature, atmospheric pressure),
- the identification parameters of the instrument to be calibrated,
- the identification of the instruments included in the measuring system and/or instrument used for measuring the output signal.

5.4.3 Presentation of results

In general, it is recommended to present the results of a calibration in a form that can be easily evaluated by the users of the measuring instrument under calibration. It is essential to present clearly the results of the calibration and the methods of modelling or interpolation (if applicable).

In order to take into account a specific method of measurement uncertainty evaluation and calculation, the results are presented differently depending on whether the measuring instrument under calibration provides:

- an output signal in an electric unit (pressure transducers and transmitters)
- an indication in a pressure unit (digital manometers).

5.4.3.1 Case of pressure transducers and transmitters

Whatever the modelling is, calibration results may be presented in a form of the following table:

	Calibration results				Model		
	Applied pressure p_r	Applied pressure p_r	Mean of output signal	Standard deviation of output signal	Modelled indicated pressure \hat{p}_i	Deviation $\hat{p}_i - p_r$	Expanded uncertainty of measurement
	(1)	(2)	(3)	(3, 4)	(5)	(5)	(5, 6)
Increasing pressure							
Decreasing pressure							

1. The pressure measured by the reference instrument at the reference level of the instrument to be calibrated, expressed in pascals or multiples. Instead of this column, the conversion coefficient of the instrument pressure unit to the pascal can be given.
2. The pressure measured by the reference instrument at the reference level of the instrument to be calibrated, expressed in the unit of the output signal of the instrument to be calibrated.
3. Value expressed in the unit of the output signal of the instrument to be calibrated.
4. Calculated at every measurement point if at least three values are available.
5. Value expressed in the pressure unit of the instrument to be calibrated. Reporting the model in the calibration certificate is optional.
6. The uncertainty determined according to section 6.

It should be noted that the standard deviation of the input signal (generally very small) is not presented in this table because the deviation is taken into account in the uncertainty of the measurements performed with the reference instrument.

5.4.3.2 Case of digital manometers

Calibration results for digital manometer may be presented in the following table:

	Applied pressure p_r (1)	Applied pressure p_r (2)	Indicated pressure p_i (3)	Standard deviation of Measurement (3)	Deviation $p_i - p_r$ (3)	Expanded uncertainty of measurement (3,4)
Increasing pressures						
Decreasing pressures						

1. The pressure measured by the reference instrument at the reference level of the instrument to be calibrated, expressed in pascals or multiples. Instead of this column, the conversion coefficient of the instrument pressure unit to the pascal can be given.
2. Pressure measured by the reference instrument at the reference level of the instrument to be calibrated, expressed in the pressure unit of the instrument to be calibrated.
3. Value expressed in the pressure unit of the instrument to be calibrated.
4. Evaluated according to section 6.

6 DETERMINATION OF THE UNCERTAINTY OF MEASUREMENT

6.1 Common aspects of determining the uncertainty of measurement

The principal elements to be taken into account for the evaluation of the uncertainty of the calibration result for an electromechanical manometer are:

for a pressure transducer or transmitter:

- uncertainty of the reference instrument in the conditions of use (cf. calibration certificate, long term stability, environmental conditions, for example)
- uncertainty due to repeatability
- uncertainty due to reversibility (hysteresis) of the instrument under calibration
- uncertainty of the measuring instruments used during the calibration (voltage, current, frequency, etc.)
- uncertainty due to influence quantities
- uncertainty due to power supply for the low-level transducers (in the case where the output signal is proportional to the supply voltage the uncertainty of measurement and the short term stability of the supply voltage have to be taken into account)
- uncertainty due to modelling (standard deviation estimated over the measured quantity)
- uncertainty due to estimation of the head correction between the instrument to be calibrated and the reference instrument

for a manometer with digital or analogue indication:

- uncertainty of the reference instrument in the conditions of use (cf. calibration certificate, long term stability, environmental conditions, for example)
- uncertainty due to repeatability
- uncertainty due to the resolution of the instrument to be calibrated
- uncertainty due to reversibility (hysteresis) of the instrument under calibration
- uncertainty due to estimation of the head correction between the instrument to be calibrated and the reference instrument

Procedure

The uncertainty of the calibration results shall be evaluated following the principles published in the EA document 4/02.

When analysing the uncertainty budget, the following terms and rules of calculation are used assuming that no correlation between the input quantities must be taken into consideration:

Table 1

Model function			$y = f(x_1, x_2, \dots, x_N)$
Standard uncertainty of measurement	$u(x_i)$	the standard uncertainty associated with the input quantity x_i	
	c_i	sensitivity coefficient	$c_i = \partial f / \partial x_i$
	$u_i(y)$	contribution to the standard uncertainty associated with the result, caused by the standard uncertainty $u(x_i)$ of the input quantity x_i	$u_i(y) = c_i \cdot u_i(x_i)$
	$u(y)$	standard uncertainty associated with the result	$u^2(y) = \sum_{i=1}^N u_i^2(y)$ $u(y) = \sqrt{\sum_{i=1}^N u_i^2(y)}$
Expanded uncertainty of measurement	$U(y)$	expanded uncertainty of measurement	$U(y) = k \cdot u(y)$
	k	coverage factor	$k = 2^{1)}$

1) The expanded uncertainty of measurement $U(y)$ shall encompass the shortest possible interval with a coverage probability of 95%. The coverage factor k is implicitly defined by $U(y) = k \cdot u(y)$. If, as is usually the case in practice, the probability distribution associated with the measurand is normal (Gaussian) then $U(y)$ shall be taken as $2 u(y)$, i.e. $k = 2$.

If relative uncertainties are used, the variables u , U are replaced by the variables w , W .

In addition to this general rule of calculating uncertainties there are two special cases which lead to sensitivity coefficients $c_i = \pm 1$:

Sum / difference model

$$Y = X + \sum_{i=1}^N \delta X_i \quad (1)$$

Y	output quantity
X	input quantity/quantities on which the measurand depends
δX_i	uncorrected error(s)
$E[\delta X_i] = 0$	expected values [no contributions to the output quantity but to the uncertainty of measurement]

This model is suited to determine, for example, the errors of indicating pressure gauges:

$$\Delta p = p_{\text{indication}} - p_{\text{standard}} + \sum_{i=1}^N \delta p_i \quad (2)$$

Product / quotient model

$$Y = X \cdot \prod_{i=1}^N K_i \quad (3)$$

Y	output quantity
X	input quantity/quantities on which the measurand depends
$K_i = (1 + \delta X_i)$	correction factor(s)
δX_i	uncorrected error(s)
$E[\delta X_i] = 0 ; E[X_i] = 1$	expected values [no contributions to the output quantity but to the uncertainty of measurement]

Suited to determine, for example, the transmission coefficient of a pressure transducer with electrical output using related (relative) uncertainties of measurement:

$$S = \frac{X_{\text{output}}}{X_{\text{input}}} = \frac{V_{\text{indication}} / (G \cdot V_{\text{PS}})}{p_{\text{standard}}} \cdot \prod_{i=1}^N K_i \quad (\text{PS} = \text{power supply}) \quad (4)$$

Input quantities

The uncertainties of measurement associated with the input quantities are grouped into two categories according to the way in which they have been determined:

Type A: The value and the associated standard uncertainty are determined by methods of statistical analysis for measurement series carried out under repeatability conditions

Type B: The value and the associated standard uncertainty are determined on the basis of other information, for example:

- previous measurement data (for example from type approvals)
- general knowledge of and experience with the properties and the behaviour of measuring instruments and materials
- manufacturer's specifications
- calibration certificates or other certificates
- reference data taken from handbooks

In many cases, only the upper and lower limits a_+ and a_- can be stated for the value of a quantity, and a probability distribution with constant probability density between these limits can be assumed. This situation is described by a rectangular probability distribution.

6.2 Guidance on uncertainty calculation for selected practical cases

6.2.1 Calibration of a digital manometer

Choice of the model

The sum/difference model is used to determine the indication error and its uncertainty separately for values measured at increasing and decreasing pressure:

$$\Delta p = p_{\text{indication}} - p_{\text{standard}} + \sum_{j=1}^2 \delta p_j = p_{\text{indication}} - p_{\text{standard}} + \delta p_{\text{zero-error}} + \delta p_{\text{repeatability}} \quad (5)$$

The symbols are explained in table 2.

Table 2

$Y = \Delta p$	measurand (= error of the indication)
$X_1 = p_{\text{indication}}$	indication of the pressure gauge
$X_2 = p_{\text{standard}}$	pressure generated by reference standard ¹
$X_3 = \delta p_{\text{zero-error}}$	uncorrected measurement error due to zero error
$X_4 = \delta p_{\text{repeatability}}$	measurement error due to repeatability

p_{standard} is assumed to be constant during the different pressure cycles. If the changes are significant regarding the resolution of $p_{\text{indication}}$, corrections will be applied to move them to the same value of p_{standard} .

Mean values of indication:

$$\bar{p}_{\text{indication}} = \frac{p_{\text{indication,up}} + p_{\text{indication,dn}}}{2} \quad (6)$$

To calculate the error $\bar{\Delta p}$ of the mean indication, the contribution of the hysteresis effect has to be taken into account:

$X_5 = \delta p_{\text{hysteresis}}$	uncorrected measurement error due to hysteresis
--------------------------------------	---

$$\begin{aligned} \bar{\Delta p} &= \bar{p}_{\text{indication}} - p_{\text{standard}} + \sum_{j=1}^2 \delta p_j \\ &= \bar{p}_{\text{indication}} - p_{\text{standard}} + \delta p_{\text{zero-error}} + \delta p_{\text{repeatability}} + \delta p_{\text{hysteresis}} \end{aligned} \quad (7)$$

A further contribution $\delta p_{\text{resolution}}$ must be added to account for the limited resolution of the indication (in table 3 given by the variability interval $2a = r$).

Uncertainty calculation

When the series at increasing (up) and decreasing (down \equiv dn) pressures are analysed separately, the expanded uncertainty of measurement ($k = 2$) becomes

$$U_{\text{up/dn}} = k \sqrt{u_{\text{standard}}^2 + u_{\text{resolution}}^2 + u_{\text{zero-error}}^2 + u_{\text{repeatability}}^2} \quad (8)$$

¹ The pressure generated by the reference standard in the reference level of the calibration object must be corrected for the influence of the conditions of use. In consequence, the uncertainty analysis also covers uncertainty components which take the difference between reference and calibration conditions into account.

In the applications of the calibration object it is often useful to combine the expanded uncertainty U with the error Δp . This provides information about the maximum deviation of one single measurement result from the correct value (as issued from the value that would have been measured with the standard instrument).

For this purpose, a so-called error span² U' can be defined:

$$U'_{\text{up/dn}} = U_{\text{up/dn}} + |\Delta p| \quad (9)$$

To calculate the uncertainty of the mean values of increasing and decreasing pressure series, the contribution of the hysteresis effect must be included:

$$U_{\text{mean}} = k \sqrt{u_{\text{standard}}^2 + u_{\text{resolution}}^2 + u_{\text{zero-error}}^2 + u_{\text{repeatability}}^2 + u_{\text{hysteresis}}^2} \quad (10)$$

The error span U'_{mean} is obtained accordingly using the greatest value of the repeatability estimated by increasing and decreasing pressure series:

$$U'_{\text{mean}} = U_{\text{mean}} + |\overline{\Delta p}| \quad (11)$$

Information available about the input quantities

The knowledge about the input quantities can be summarised in a table:

² The error span is the maximum difference to be expected between the measured value and the conventional true value of the measurand. The error span can be used in technical specifications to characterise the accuracy of the calibrated instrument.

Table 3

No.	Quantity	Estimate	Unit ³	Variability interval	Probability distribution	Divisor	Standard uncertainty	Sensitivity coefficient	Contribution to uncertainty
	X_j	x_j		$2a$	$P(x_j)$		$u(x_j)$	c_j	$u_j(y)$
1	$\bar{p}_{\text{indication}}$ or $\bar{p}_{\text{indication}}$	$\bar{p}_{i,\text{indic}}$ or $\bar{p}_{i,\text{indic}}$	bar	r (resolution)	Rectangular	$\sqrt{3}$	$u(r) = \sqrt{\frac{1}{3} \cdot \left(\frac{r}{2}\right)^2}$	1	u_r
2	p_{standard}	$p_{i,\text{standard}}$	bar		Normal	2	$u(p_{\text{standard}})$	-1	u_{standard}
3	$\delta p_{\text{zero error}}$	0	bar	f_0	Rectangular	$\sqrt{3}$	$u(f_0) = \sqrt{\frac{1}{3} \cdot \left(\frac{f_0}{2}\right)^2}$	1	u_{f_0}
4	δp_{repeat}	0	bar	b'	Rectangular	$\sqrt{3}$	$u(b') = \sqrt{\frac{1}{3} \cdot \left(\frac{b'}{2}\right)^2}$	1	$u_{b'}$
5	$\delta p_{\text{hysteresis}}$	0	bar	h	Rectangular	$\sqrt{3}$	$u(h) = \sqrt{\frac{1}{3} \cdot \left(\frac{h}{2}\right)^2}$	1	u_h
	Y	$\frac{\Delta p}{\Delta p}$ or $\frac{\Delta p}{\Delta p}$	bar						$u(y)$

Note: 1) The formulae recommended to determine the quantities f_0 , b' and h from a limited set of measured data are defined by equations 18 to 25 in the section *Determination of the characteristic values significant for the uncertainty*.

2) If sufficient data are available, the repeatability should be expressed by the empirical standard deviation.

Statement of a single value

In addition to the error span for each calibration pressure, the maximum error span in the range covered by the calibration (in pressure units or related to the measured value or the measurement span) may be stated. Compliance with specified maximum permissible errors can also be confirmed (statement of compliance).

6.2.2 Calibration of a pressure transducer with electrical output

Choice of the model

Usually the dependence of the output quantity of a pressure transducer (any electrical quantity) on the input quantity (the pressure) is described by a so-called characteristic $Y = f(p)$, generally a straight line passing through $Y = 0$ or some defined point $Y = Y_0$ and having a slope adjusted by the manufacturer to meet a specified value within certain limits. The calibration of the pressure transducer can now be based on the model equation

$$\Delta Y = Y - f(p_{\text{standard}}) + \sum (\delta Y)_i \quad (12)$$

³ It is recommended to state the unit of the uncertainty contributions (unit of the physical quantity, unit of indication, related (dimensionless) quantity, etc.).

where the function $f(p)$ is regarded as defined in the mathematical sense, i.e. in the case of a polynomial by coefficients without uncertainties, and the output quantity Y has values y_i measured at the calibration pressures p_i obtained from the standard.

Equation (12) corresponds to equation (5) and the sum/difference model can be used to determine the error ΔY and its uncertainty separately for values measured at increasing and decreasing pressure or for the mean values. However, contributions $(\delta Y)_{\text{indication}}$ must be included to account for the measurement uncertainty of the instruments used to measure the output signal of the transducer.

A formally different approach is to determine the transmission coefficient S - again separately for values measured at increasing and decreasing pressures, and for the mean values -, using the product / quotient model:

$$S = \frac{X_{\text{output}}}{X_{\text{input}}} = \frac{V_{\text{indication}} / (GV_{\text{PS}})}{p_{\text{standard}}} \prod_{i=1}^2 K_i = \frac{V_{\text{indication}} / (GV_{\text{PS}})}{p_{\text{standard}}} K_{\text{zero-error}} K_{\text{repeatability}} \quad (13)$$

Table 4

$Y = S$	measurand; transmission coefficient
$X_1 = V_{\text{indication}}$	indication of the output device (voltmeter)
$X_2 = G$	transmission coefficient of amplifier
$X_3 = V_{\text{PS}}$	power supply voltage (auxiliary device)
$X_4 = p_{\text{standard}}$	pressure generated by the reference standard
$X_5 = K_{\text{zero-error}}$	correction factor for zero error
$X_6 = K_{\text{repeatability}}$	correction factor for repeatability
$X_7 = K_{\text{reproducibility}}$	if appropriate, correction factor for reproducibility (for example, when the effect of torque is estimated during the calibration)
$X_8 = K_{\text{hysteresis}}$	correction factor for hysteresis

The corresponding result for the mean values of the transmission coefficient is obtained by including the correction factor for hysteresis:

$$S = \frac{X_{\text{output}}}{X_{\text{input}}} = \frac{V_{\text{indication}} / (GV_{\text{PS}})}{p_{\text{standard}}} \prod_{i=1}^3 K_i \quad (14)$$

$$= \frac{V_{\text{indication}} / (GV_{\text{PS}})}{p_{\text{standard}}} K_{\text{zero-error}} K_{\text{repeatability}} K_{\text{hysteresis}}$$

Uncertainty calculation

When the increasing and decreasing pressure series are analysed separately, the relative expanded uncertainty ($k = 2$) of the transmission coefficient is obtained as

$$W_{\text{up/dn}} = k \sqrt{w_{\text{standard}}^2 + w_{\text{indication}}^2 + w_{\text{amplifier}}^2 + w_{\text{power-supply}}^2 + w_{\text{zero-error}}^2 + w_{\text{repeatability}}^2} \quad (15)$$

When the mean value of the increasing and decreasing pressure series is used,

$$W_{\text{mean}} = k \sqrt{w_{\text{standard}}^2 + w_{\text{indication}}^2 + w_{\text{amplifier}}^2 + w_{\text{supply}}^2 + w_{\text{zero-error}}^2 + w_{\text{repeatability}}^2 + w_{\text{hysteresis}}^2} \quad (16)$$

with the greatest value of the repeatability at each calibration pressure being used to calculate the measurement uncertainty $w_{\text{up/dn}}$.

The relative error span is
$$W'_{\text{mean}} = W_{\text{mean}} + \left| \frac{\Delta S}{S} \right| \quad (17)$$

with $\Delta S = S - S_0$

The single transmission coefficient (S_0) is preferably the slope of the straight line fitted through all measured values of the output signal.

Information available about the input quantities

The knowledge about the input quantities can be summarised in a table.

Table 5

Comp. N°.	Quantity	Estimate	Variability interval	Probability distribution	Divisor	Standard uncertainty of measurement	Sensitivity coefficient	Contribution to the uncertainty
	X_i	x_i	$2a$	$p(x_i)$		$w(x_i)$	c_i	$w_i(y)$
1	$V_{\text{indication}}$ or $\bar{V}_{\text{indication}}$	V_i indic. or $\bar{V}_{i, \text{indic.}}$		normal	2	w (indicating device)	1	$w_{\text{indication}}$
2	G	G		normal	2	w (amplifier)	-1	$w_{\text{amplifier}}$
3	V_{PS}	V_{PS}		normal	2	w (power supply)	-1	$w_{\text{power-supply}}$
4	ρ_{standard}	$\rho_{i, \text{stand.}}$		normal	2	w (standard)	-1	w_{standard}
5	$K_{\text{zero-error}}$	1	f_0	rectangular	$\sqrt{3}$	$w(f_0) = \sqrt{\frac{1}{3} \cdot \left(\frac{f_0}{2}\right)^2}$	1	w_{f_0}
6	$K_{\text{repeatability}}$	1	b'	rectangular	$\sqrt{3}$	$w(b') = \sqrt{\frac{1}{3} \cdot \left(\frac{b'}{2}\right)^2}$	1	$w_{b'}$
7	$K_{\text{reproducibility}}$	1	b	rectangular	$\sqrt{3}$	$w(b) = \sqrt{\frac{1}{3} \cdot \left(\frac{b}{2}\right)^2}$	1	w_b
8	$K_{\text{hysteresis}}$	1	h	rectangular	$\sqrt{3}$	$w(h) = \sqrt{\frac{1}{3} \cdot \left(\frac{h}{2}\right)^2}$	1	w_h
	Y	S or S'						$w(y)$

The following is of importance in order to understand table 5:

1. The characteristic quantities f_0 , b' , b and h here are *relative* quantities, i.e. quantities related to the measured value (the indication).
2. In the determination of the transmission factor the zero point is *not* a calibration point. Despite this, the zero shift observed enters into the uncertainty of the measured values of the output signal and thus influences the uncertainty of the calibration result for the output quantity S .

Determination of the characteristic values significant for the uncertainty

Preliminary remark: According to page 15, the type A contributions to the uncertainty should be stated in the form of empirical standard deviations. In the case of measuring instruments affected by hysteresis, where the measurements in the direction of increasing

and decreasing pressures must be evaluated separately, a maximum of only three measured values is available at each calibration point and the assumption that these values are normally distributed is often not justified. Some simple formulas are, therefore, given in the following, which are not based on statistical assumptions and which, according to experience, furnish useful substitutes for the standard deviations. Their application is, however, optional.

Resolution r

The resolution corresponds to the digit step, provided the indication does not vary by more than one digit step when the pressure measuring device is unloaded.

If, with the pressure measuring device unloaded, the indication varies by more than the value of the resolution determined before, a variability interval $2a = r$ of a rectangular distribution is to be estimated.

Zero error f_0

The zero point *may* be set prior to each measurement cycle comprising one measurement series each at increasing and decreasing pressures, and it *must* be recorded prior to and after each measurement cycle. The reading must be taken after complete removal of the load. The zero error is calculated as follows:

$$f_0 = \max\{|x_{2,0} - x_{1,0}|, |x_{4,0} - x_{3,0}|, |x_{6,0} - x_{5,0}|\} \quad (18)$$

The indices number the measured values x read at the zero points of measurement series M1 to M6.

Repeatability b'

The repeatability, with the mounting unchanged, is determined from the difference between the values measured in corresponding measurement series, corrected by the zero signal (the index j numbers the nominal pressure values; $j = 0$: zero point):

$$b'_{up,j} = \text{MAX}\{ |(x_{3,j} - x_{3,0}) - (x_{1,j} - x_{1,0})|, |(\underline{x_{5,j} - x_{5,0}}) - (x_{1,j} - x_{1,0})|, |(\underline{x_{5,j} - x_{5,0}}) - (x_{3,j} - x_{3,0})| \} \quad (19)$$

$$b'_{dn,j} = \text{MAX}\{ |(x_{4,j} - x_{4,0}) - (x_{2,j} - x_{2,0})|, |(\underline{x_{6,j} - x_{6,0}}) - (x_{2,j} - x_{2,0})|, |(\underline{x_{6,j} - x_{6,0}}) - (x_{4,j} - x_{4,0})| \} \quad (20)$$

$$b'_{mean,j} = \text{MAX}\{b'_{up,j}, b'_{dn,j}\} \quad (21)$$

The underlined terms are missing if the third series of measurements is performed after reinstallation to check reproducibility. In this case:

$$\text{Reproducibility } b \quad b_{up,j} = \text{MAX}\{ |x_{5,j} - x_{5,0}| - (x_{1,j} - x_{1,0}) | \} \quad (22)$$

$$b_{dn,j} = \text{MAX}\{ |x_{6,j} - x_{6,0}| - (x_{2,j} - x_{2,0}) | \} \quad (23)$$

$$b_{mean,j} = \text{MAX}\{b_{up,j}, b_{dn,j}\} \quad (24)$$

Hysteresis h (Reversibility)

The hysteresis is determined from the difference between corresponding indications / output values measured at increasing and decreasing pressures:

$$h_j = \frac{1}{3} \left(|x_{2,j} - x_{1,j}| + |x_{4,j} - x_{3,j}| + |x_{6,j} - x_{5,j}| \right) \quad (25)$$

7 EXAMPLES

General remarks

Two examples have been chosen:

Example 1: Calibration of an indicating digital pressure gauge. The numerical results are presented in table E1 and are visualised in figure 7.

Example 2: Calibration of a pressure transducer. Example 2 is presented in two different ways:

Example 2a is based on the defined linear characteristic of the instrument. The pressures calculated from the measured output signals using this characteristic are compared with the pressures obtained from the standard instrument. The sum/difference model is applied to calculate the uncertainty of measurement using procedures described in paragraph "Determination of the characteristic values significant for the uncertainty" (page 21). The numerical results are presented in table E2a and are visualised in figure 8.

In example 2b the transmission factor of the same instrument is determined at the same calibration points. Zero error, repeatability, reproducibility and hysteresis are calculated using the formulae presented on page 22. The numerical results are presented in table E2b and are visualised in figure 9.

By figure 8 it is demonstrated that the calibration methods 2a and 2b are equivalent:

The error spans $U^*(p_{\text{indicated}})$ plotted in figure 8 can be calculated from the error spans $U^*(S_{p \text{ ind.}})$ of the values of the transmission factor S as

$$\begin{aligned} U^*(p_{\text{indicated}}) &= U^*(S_{p \text{ ind.}}) \cdot p_{\text{ind}} \cdot \frac{100}{(1/S)_{\text{nominal value}}} = U^*_{\text{rel}}(S_{p \text{ ind.}}) p_{\text{ind.}} \\ [\text{bar}] &= [\text{mV/V} \cdot \text{bar}] \cdot [\text{bar}] \cdot [\text{bar}/(\text{mV/V})] \end{aligned}$$

In figure 8 the values of $U^*(p_{\text{indicated}})$ as obtained in example 2a are indicated as open circles whereas the corresponding values obtained from the results of example 2b are indicated as open squares. Ideally the circles and the squares should coincide. The differences reflect the differences in the methods of calculating the components $u(y)$ in both examples. Obviously the overall result does not depend very much on such differences which was to be demonstrated.

7.1 Example 1 - Calibration of an indicating digital pressure gauge

Calibration object:

Indicating digital pressure gauge

Range: 0 MPa to 25 MPa (gauge)

Resolution: 0.01 kPa

Reference temperature: 20 °C

Note: At pressures below some small critical value the zero reading appears at the display. The zero reading does not correspond exactly to $p_e = 0$.

Calibration procedure

Before calibration the instrument was twice brought to its nominal pressure and kept at this pressure for one minute.

The difference Δh in height between the pressure reference levels of the calibration object and the standard instrument was adjusted to zero.

Calibration temperature = reference temperature \pm 0.5 K

Three complete series of comparison measurements were carried out (comprehensive calibration procedure).

Standard instrument

The standard instrument was an oil-operated pressure balance operated at piston-cylinder temperature t_{std} , and at ambient pressure p_{amb} and ambient temperature t_{amb} , i.e. at an air density $\rho_{\text{air}}(p_{\text{amb}}, t_{\text{amb}}, 60\% \text{ rel. humidity})$.

The expanded uncertainty of the pressures measured at calibration conditions in the reference level of the calibration object is

$$U(p_e) = 0.02 \text{ kPa} + 8.0 \cdot 10^{-5} \cdot p_e$$

Evaluation of the uncertainty of measurement

The uncertainty of the observed difference between the indicated pressure and the correct value of the pressure as obtained from the standard instrument is calculated from the sum/difference model separately for pressures measured at increasing and decreasing pressures. The uncertainty of the mean values of the indicated pressure is calculated by adding the uncertainty contribution due to reversibility (hysteresis). If no corrections are applied to the readings, the accuracy of the pressures measured with the calibrated instrument is given by its error span (uncertainty + deviation).

Table E1: CALIBRATION OF A DIGITAL MANOMETER / NUMERICAL RESULTS

Expanded uncertainty of applied pressure	Applied pressure p_r	Applied pressure p_r	Mean reading p_i	Variability interval $b_{up}; b_{down}$		Deviation $p_i - p_r$	Expanded uncertainty of measurement U	
kPa	MPa	bar	bar	bar		bar	bar	
0.02	0.0000	0.000	0.000	0.000		0.000	0.001	
0.22	2.5015	25.015	24.931	0.054		-0.084	0.031	
0.42	5.0029	50.029	49.952	0.033		-0.077	0.019	
0.62	7.5043	75.043	74.956	0.031		-0.087	0.019	
0.82	10.0057	100.057	99.983	0.019		-0.075	0.014	
1.02	12.5072	125.072	124.996	0.045		-0.075	0.028	
1.22	15.0086	150.086	150.021	0.032		-0.064	0.022	
1.42	17.5099	175.099	175.029	0.041		-0.071	0.028	
1.62	20.0113	200.113	200.066	0.055		-0.047	0.036	
1.82	22.5127	225.127	225.064	0.035		-0.063	0.027	
2.02	25.0140	250.140	250.078	0.046		-0.062	0.033	
2.02	25.0140	250.140	250.086	0.036		-0.054	0.029	
1.82	22.5127	225.127	225.082	0.038		-0.045	0.029	
1.62	20.0113	200.113	200.054	0.048		-0.059	0.032	
1.42	17.5099	175.099	175.058	0.011		-0.041	0.016	
1.22	15.0085	150.085	150.044	0.036		-0.041	0.024	
1.02	12.5071	125.071	125.017	0.030		-0.054	0.020	
0.82	10.0057	100.057	100.001	0.035		-0.056	0.022	
0.62	7.5043	75.043	74.979	0.034		-0.064	0.021	
0.42	5.0029	50.029	49.982	0.023		-0.047	0.014	
0.22	2.5015	25.015	24.945	0.027		-0.070	0.016	
0.02	0.0000	0.000	0.000	0.000		0.000	0.001	
Expanded uncertainty of appl. pressure	Mean appl. pressure $p_{r,mean}$	Mean appl. pressure $p_{r,mean}$	Mean reading p_i	b_{mean} of corresponding series	Hysteresis $p_{i-up} - p_{i-dn}$	Deviation $p_i - p_r$	Expanded uncertainty of measurement U	Error span
kPa	MPa	bar	bar	bar	bar	bar	bar	bar
0.02	0.0000	0.000	0.000	0.000	0.000	0.000	0.001	0.001
0.22	2.5015	25.015	24.938	0.054	0.014	-0.077	0.033	0.109
0.42	5.0029	50.029	49.967	0.033	0.030	-0.062	0.026	0.088
0.62	7.5043	75.043	74.968	0.034	0.023	-0.075	0.025	0.100
0.82	10.0057	100.057	99.992	0.035	0.018	-0.065	0.024	0.089
1.02	12.5071	125.071	125.007	0.045	0.021	-0.065	0.030	0.095
1.22	15.0085	150.085	150.033	0.036	0.023	-0.053	0.028	0.080
1.42	17.5099	175.099	175.043	0.041	0.029	-0.056	0.032	0.088
1.62	20.0113	200.113	200.060	0.055	-0.012	-0.053	0.036	0.089
1.82	22.5127	225.127	225.073	0.038	0.018	-0.054	0.030	0.084
2.02	25.0140	250.140	250.082	0.046	0.008	-0.058	0.034	0.092

UNCERTAINTY BUDGET AT CALIBRATION PRESSURE 100 bar

Quantity	Estimate	Variability interval (2 σ)	Probability distribution	Divisor	Standard uncertainty	Sensitivity coefficient	Contribution to uncertainty	Variance
X_j	x_j				$u(x_j)$	c_j	$u_j(y)$	
$p_{standard}$	100.057 bar	0.016 bar	normal	2	0.0041 bar	-1	-0.0041 bar	1.68E-05 bar ²
$p_{reading}$	99.992 bar	0.001 bar	rectangular	$\sqrt{3}$	2.89*10E-04 bar	1	2.89E-04 bar	8.35E-08 bar ²
δp_{zero} error	0.000 bar	0.000 bar						
$\delta p_{repeatability}$	0.000 bar	0.035 bar	rectangular	$\sqrt{3}$	0.0101 bar	1	0.0101 bar	1.02E-04 bar ²
$\delta p_{hysteresis}$	0.000 bar	0.018 bar	rectangular	$\sqrt{3}$	0.0053 bar	1	0.0053 bar	2.80E-05 bar ²
Δp	-0.065 bar						1.21E-02 bar	1.47E-04 bar ²

$\Delta p = -0.065 \text{ bar}$

$U = k \cdot u = 0.024 \text{ bar}$

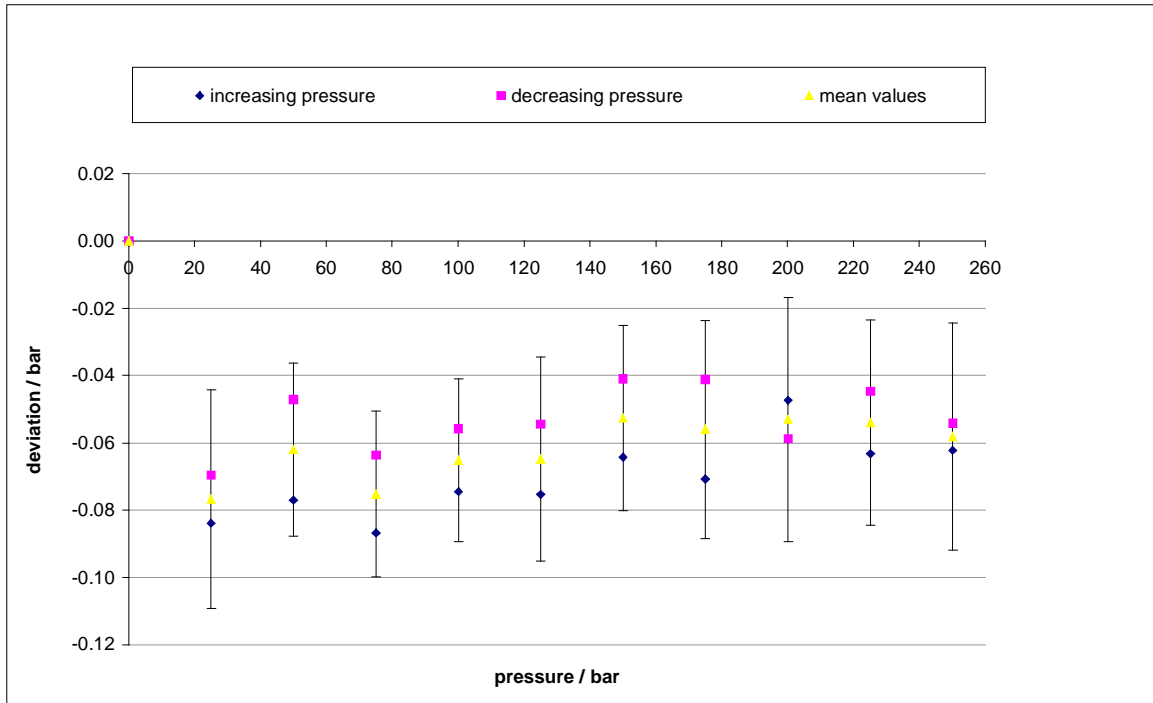

Error bars: Expanded uncertainty of mean values

Figure 7 - Calibration of a digital manometer

7.2 Example 2 - Calibration of a pressure transducer

1. by using a linear characteristic to model the output signal (Example 2a)
2. by determining the transmission factor (Example 2b)

Calibration object:

Pressure transducer with *Wheatstone* bridge on metal diaphragm as sensing element. Range: 20 MPa. Reference temperature: 20 °C.

Calibration procedure

The output signal of the pressure transducer was measured in units [mV/V] using a digital compensator the expanded measurement uncertainty of which was 0.00005 mV/V.

Before calibration the instrument was twice brought to its maximum pressure and kept at this pressure for one minute.

The difference Δh in height between the pressure reference levels of the calibration object and the standard instrument was adjusted to zero.

The calibration temperature was equal to the reference temperature within ± 0.5 K.

Three complete series of comparison measurements were carried out (comprehensive calibration procedure).

Standard instrument

The standard instrument was an oil-operated pressure balance operated at piston-cylinder temperature t_{std} , and at ambient pressure p_{amb} and ambient temperature t_{amb} , i.e. at an air density $\rho_{\text{air}}(p_{\text{amb}}, t_{\text{amb}}, 60\% \text{ rel. humidity})$.

The expanded uncertainty of the pressures measured at calibration conditions in the reference level of the calibration object is $U(p_e) = 1.0 \cdot 10^{-4} \cdot p_e$ for $p_e > 1 \text{ MPa}$.

Evaluation of the uncertainty of measurement

The uncertainty of the observed difference $\Delta(p)$ between the pressure calculated from the characteristic straight line and the correct value of the pressure as obtained from the standard instrument is calculated from the sum/difference model separately for pressures measured at increasing and decreasing pressures. The uncertainty of the mean values of $\Delta(p)$ is calculated by adding the uncertainty contribution due to reversibility (hysteresis). If no corrections are applied to the readings, the accuracy of the pressures measured with the calibrated instrument is given by its error span (uncertainty + deviation).

Note: The slope of the linear characteristic is obtained from a straight line fitted to the calibration data. It replaces the nominal value $1.000000 \text{ E-02 mV/(V}\cdot\text{bar)}$ (corresponding to an output signal of 2 mV/V FS) as defined by the manufacturer and - like the nominal value - has to be regarded as a **defined value** without uncertainty.

Table E2a: CALIBRATION OF A PRESSURE TRANSDUCER / NUMERICAL RESULTS

Expanded uncertainty of appl. press.	Applied pressure p_r	Applied pressure p_r	Mean output signal f_{mean}	Variability interval $b_{up}; b_{down}$	Variability interval $b_{up}; b_{down}$	Expand. unc. of output sig. measur.	Modelled indicated pressure	Deviation $p_i - p_r$	Uncertainty of measurement
kPa	Mpa	bar	mV/V	mV/V	mV/V	mV/V	p_i / bar	bar	bar
0.00	0.0000	0.000	0.000000	0.000000	0.000000	0.000050	0.000	0.000	0.010
0.20	2.0010	20.010	0.200163	0.000100	0.000120	0.000050	20.013	0.003	0.014
0.40	4.0022	40.022	0.400303	0.000060	0.000070	0.000050	40.024	0.003	0.013
0.60	6.0033	60.033	0.600463	0.000080	0.000080	0.000050	60.037	0.004	0.014
0.80	8.0045	80.045	0.800590	0.000090	0.000090	0.000050	80.047	0.002	0.016
1.00	10.0056	100.056	1.000700	0.000090	0.000120	0.000050	100.055	-0.001	0.018
1.20	12.0068	120.068	1.200787	0.000060	0.000080	0.000050	120.061	-0.007	0.018
1.40	14.0079	140.079	1.400863	0.000090	0.000100	0.000050	140.065	-0.014	0.020
1.60	16.0091	160.091	1.600880	0.000090	0.000090	0.000050	160.064	-0.027	0.022
1.80	18.0102	180.102	1.800907	0.000130	0.000070	0.000050	180.063	-0.038	0.024
2.00	20.0113	200.113	2.000843	0.000090	0.000070	0.000050	200.054	-0.059	0.023
2.00	20.0113	200.113	2.001003	0.000090	0.000000	0.000050	200.070	-0.043	0.021
1.80	18.0102	180.102	1.801313	0.000180	0.000380	0.000050	180.104	0.002	0.031
1.60	16.0091	160.091	1.601437	0.000140	0.000320	0.000050	160.119	0.029	0.027
1.40	14.0079	140.079	1.401470	0.000130	0.000260	0.000050	140.126	0.047	0.023
1.20	12.0068	120.068	1.201407	0.000130	0.000180	0.000050	120.123	0.055	0.019
1.00	10.0056	100.056	1.001330	0.000090	0.000150	0.000050	100.118	0.062	0.016
0.80	8.0045	80.045	0.801160	0.000030	0.000090	0.000050	80.104	0.059	0.013
0.60	6.0033	60.033	0.600943	0.000020	0.000030	0.000050	60.085	0.052	0.011
0.40	4.0022	40.022	0.400647	0.000010	0.000000	0.000050	40.059	0.037	0.010
0.20	2.0010	20.010	0.200303	0.000020	0.000050	0.000050	20.027	0.017	0.010
0.00	0.0000	0.000	-0.000010	0.000000	0.000000	0.000050	-0.001	-0.001	0.000

Modelled pressure: $p_i = c \cdot f_{mean}$ $c = 99.9849 \text{ bar}/(\text{mV}/\text{V})$

Mean appl. pressure p_r, mean	Mean output signal	Variability interval of corresponding series		Hysteresis $p_{up} - p_{dn}$	Modelled indicated pressure	Deviation $p_i - p_r$	Uncertainty of measurement	Error span	Error span calcul. from tr. coeff. *)
bar	mV/V	b_{mean} mV/V	b_{mean} mV/V	mV/V	p_i / bar	bar	bar	bar	bar
0.000	-0.000005	0.000090	0.000026	-0.000010	0.000	0.000	0.011	0.012	
20.010	0.200233	0.000180	0.000120	0.000140	20.020	0.010	0.027	0.037	0.024
40.022	0.400475	0.000140	0.000070	0.000343	40.041	0.020	0.027	0.046	0.041
60.033	0.600703	0.000130	0.000080	0.000480	60.061	0.028	0.034	0.062	0.058
80.045	0.800875	0.000130	0.000090	0.000570	80.075	0.031	0.040	0.070	0.065
100.056	1.001015	0.000090	0.000150	0.000630	100.086	0.030	0.038	0.068	0.070
120.068	1.201097	0.000060	0.000180	0.000620	120.092	0.024	0.053	0.077	0.064
140.079	1.401167	0.000090	0.000260	0.000607	140.096	0.016	0.065	0.081	0.058
160.091	1.601158	0.000090	0.000320	0.000557	160.092	0.001	0.074	0.075	0.042
180.102	1.801110	0.000130	0.000380	0.000407	180.084	-0.018	0.082	0.100	0.057
200.113	2.000923	0.000090	0.000230	0.000160	200.062	-0.051	0.052	0.103	0.075

*) see table E2b for comparison with the other way of estimating the error span

UNCERTAINTY BUDGET AT CALIBRATION PRESSURE 100 bar

Quantity	Estimate	Variability interval (2a)	Probability distribution	Divisor	Standard uncertainty $u(x_j)$	Sensitivity coefficient c_j	Contribution to std. unc. $u_j(y)$	Variance
X_j	x_j				$u(x_j)$	c_j	$u_j(y)$	
$p_{standard}$	100.056 bar	0.020 bar	normal	2	0.005 bar	-1	-0.005 bar	2.50E-05 bar ²
output signal (electrical)	1.001015 mV/V	0.000100 mV/V	normal	2	0.000025 mV/V	99.9849 bar/(mV/V)	0.002 bar	6.25E-06 bar ²
output signal (repeatability)	1.001015 mV/V	0.000150 mV/V	rectangular	√3	0.000043 mV/V	99.9849 bar/(mV/V)	0.004 bar	1.87E-05 bar ²
output signal (reproducib.)	1.001015 mV/V	0.000090 mV/V	rectangular	√3	0.000026 mV/V	99.9849 bar/(mV/V)	0.003 bar	6.75E-06 bar ²
hysteresis	0.000000 mV/V	0.000630 mV/V	rectangular	√3	0.000182 mV/V	99.9849 bar/(mV/V)	0.018 bar	3.31E-04 bar ²
δp	0.030 bar						0.020 bar	3.87E-04 bar ²
$\delta p =$	0.030 bar					U = k · u =	0.039 bar	

Table E2b Calibration of a pressure transducer by measurement of its transmission factor / Numerical results

Measured data

Applied pressure	Expanded relat. uncertainty	Output signal					
		/ Digital compensator					
p_{standard}	$W(p_{\text{standard}})$	M1	M2	M3	M4	M5	M6
bar		mV/V	mV/V	mV/V	mV/V	mV/V	mV/V
0.000		0.00000	-0.00003	0.00000	0.00002	0.00000	-0.00002
20.010	$1.0 \cdot 10^{-4}$	0.20009	0.20026	0.20019	0.20033	0.20021	0.20032
40.022	$1.0 \cdot 10^{-4}$	0.40026	0.40063	0.40032	0.40067	0.40033	0.40064
60.033	$1.0 \cdot 10^{-4}$	0.60041	0.60094	0.60049	0.60097	0.60049	0.60092
80.045	$1.0 \cdot 10^{-4}$	0.80053	0.80118	0.80062	0.80120	0.80062	0.80110
100.056	$1.0 \cdot 10^{-4}$	1.00063	1.00139	1.00072	1.00135	1.00075	1.00125
120.068	$1.0 \cdot 10^{-4}$	1.20074	1.20149	1.20080	1.20141	1.20082	1.20132
140.079	$1.0 \cdot 10^{-4}$	1.40080	1.40158	1.40089	1.40150	1.40090	1.40133
160.091	$1.0 \cdot 10^{-4}$	1.60082	1.60157	1.60091	1.60148	1.60091	1.60126
180.102	$1.0 \cdot 10^{-4}$	1.80084	1.80148	1.80097	1.80135	1.80091	1.80111
200.113	$1.0 \cdot 10^{-4}$	2.00079	2.00100	2.00088	2.00114	2.00086	2.00087

Evaluation

Applied press.	Expanded relat. uncertainty	Mean output signal	Zero error	Repeatability	Reproducibility	Hysteresis
p_{standard}	$W(I_{D.c.})$	I_{mean}	$f_{0 \text{ rel}}$	b'_{rel}	b_{rel}	h_{rel}
*)		$\Sigma M_i / 6$	$ \max / I_{\text{mean}}$	$ \max / I_{\text{mean}}$	$ \max / I_{\text{mean}}$	$(I_{\text{mean}}/3) \cdot \Sigma h_i $
bar		mV/V				
0.000		-0.000005				
20.010	$2.50 \cdot 10^{-4}$	0.200233	1.5E-04	5.0E-04	6.0E-04	7.0E-04
40.022	$1.25 \cdot 10^{-4}$	0.400475	7.5E-05	1.5E-04	1.7E-04	8.6E-04
60.033	$0.83 \cdot 10^{-4}$	0.600703	5.0E-05	1.3E-04	1.3E-04	8.0E-04
80.045	$0.63 \cdot 10^{-4}$	0.800875	3.7E-05	1.1E-04	1.1E-04	7.1E-04
100.056	$0.50 \cdot 10^{-4}$	1.001015	3.0E-05	9.0E-05	1.5E-04	6.3E-04
120.068	$0.42 \cdot 10^{-4}$	1.201097	2.5E-05	1.1E-04	1.5E-04	5.2E-04
140.079	$0.36 \cdot 10^{-4}$	1.401167	2.1E-05	9.3E-05	1.9E-04	4.3E-04
160.091	$0.32 \cdot 10^{-4}$	1.601158	1.9E-05	8.7E-05	2.0E-04	3.5E-04
180.102	$0.28 \cdot 10^{-4}$	1.801110	1.7E-05	1.0E-04	2.1E-04	2.3E-04
200.113	$0.25 \cdot 10^{-4}$	2.000923	1.5E-05	4.5E-05	7.0E-05	8.0E-05

*) In the pressure reference level of the calibration object

Result

Applied press.	Transmissi on coefficient	Error	Expanded rel. uncertainty of measurement	Expanded uncertainty of measurement	Error span
p_{standard}	S $I_{\text{mean}} / p_{\text{standard}}$	ΔS $S - 0.01000151$	$W(S)$ $2[\sum w_i^2(S)]^{0.5}$	$U(S)$ $W \cdot S$	$U^{\wedge}(S)$ $U + \Delta S$
bar	(mV/V)/ bar	(mV/V)/ bar		(mV/V)/ bar	(mV/V)/ bar
0.000					
20.010	0.01000666	0.00000515	6.7E-04	0.00000668	0.00001183
40.022	0.01000637	0.00000486	5.4E-04	0.00000539	0.00001025
60.033	0.01000622	0.00000471	4.9E-04	0.00000493	0.00000964
80.045	0.01000531	0.00000380	4.4E-04	0.00000438	0.00000818
100.056	0.01000455	0.00000304	3.9E-04	0.00000394	0.00000698
120.068	0.01000347	0.00000196	3.3E-04	0.00000335	0.00000531
140.079	0.01000269	0.00000118	3.0E-04	0.00000297	0.00000415
160.091	0.01000155	0.00000004	2.6E-04	0.00000259	0.00000263
180.102	0.01000050	-0.00000101	2.1E-04	0.00000215	0.00000316
200.113	0.00999897	-0.00000254	1.2E-04	0.00000123	0.00000377
	Single value:	0.01000151 (mV/V)/ bar			

Uncertainty budget at the calibration pressure $p = 100$ bar

Quantity	Estimate	Variability interval	Divisor	Relative standard uncertainty y	Sensitivity coefficient	Contribution to uncertainty	Variance
X_j	x_j	$2a$		$w(x_j)$	c_j	$w_j(y)$	w_j^2
p_{normal}	100.056 bar	20 mbar	2	$5.00 \cdot 10^{-5}$	-1	$5.00 \cdot 10^{-5}$	$2.50 \cdot 10^{-9}$
V_{reading}	1.001015 mV/V	0.00010 mV/V	2	$2.50 \cdot 10^{-5}$	1	$2.50 \cdot 10^{-5}$	$6.25 \cdot 10^{-10}$
$K_{\text{zero error}}$	1	$3.0 \cdot 10^{-5}$	$\sqrt{3}$	$8.66 \cdot 10^{-6}$	1	$8.66 \cdot 10^{-6}$	$7.50 \cdot 10^{-11}$
$K_{\text{repeatability}}$	1	$9.0 \cdot 10^{-5}$	$\sqrt{3}$	$2.60 \cdot 10^{-5}$	1	$2.60 \cdot 10^{-5}$	$6.76 \cdot 10^{-10}$
$K_{\text{reproducibility}}$	1	$1.5 \cdot 10^{-4}$	$\sqrt{3}$	$4.33 \cdot 10^{-5}$	1	$4.33 \cdot 10^{-5}$	$1.87 \cdot 10^{-9}$
$K_{\text{hysteresis}}$	1	$6.3 \cdot 10^{-4}$	$\sqrt{3}$	$1.82 \cdot 10^{-4}$	1	$1.82 \cdot 10^{-4}$	$3.31 \cdot 10^{-8}$
S	1.000455 E-02 (mV/V)/ bar	$w =$				1.97×10^{-4}	$\sum w_j^2 = 3.88 \times 10^{-8}$
$S = 1.000455 \text{ E-02 (mV/V)/ bar}^*)$		$W = k \cdot w$ ($k=2$)			$3.9 \cdot 10^{-4}$		

*) The transmission factor is valid for the calibration pressure $p_{\text{normal}} = 100.056$ bar. It differs in the single transmission coefficient calculated from all calibration pressures.

At the calibration pressure $p_e = 100$ bar the expanded uncertainty $U(S)$ of the value S of the transmission factor is calculated as

$$U(S) |_{100 \text{ bar}} = W \cdot S = 3.9 \cdot 10^{-4} \cdot 0.01000455 \text{ (mV/V)/ bar} = 3.9 \cdot 10^{-6} \text{ (mV/V)/ bar}$$

Statement of a single value of the transmission coefficient

The general use of a pressure transducer does not imply the application of different transmission coefficients for the individual load steps (= calibration pressures) but of only a single transmission coefficient for the total range covered by the calibration. This is preferably *the slope of the straight line fitted through all measured values of the output signal*.

When this characteristic quantity of the pressure transducer is used, a statement of compliance replaces the uncertainties associated with the individual values measured for the transmission coefficient.

This requires that the limits of permissible error be fixed, which can be done on the basis of the calibration results by calculation of the error spans i.e. by adding

- the uncertainties associated with the individual values measured for the transmission coefficient, and
- the deviations of these values from the single value stated for the transmission coefficient.

Normally, error spans results values decrease with increasing pressure (see figure 9). Two methods for fixing the limits of permissible error are possible:

- one may choose the largest calculated error span as the limiting value, or
- limiting values of the errors are described by suitable curves, e.g. polynomials.

Note: The use of pressure-dependent limiting values of the errors is not common practice. However, it allows smaller uncertainties to be stated when pressure measurements are carried out with the calibrated instrument in the upper part of the measuring range.

In the case of objects to be calibrated whose transmission coefficient has been specified by the manufacturer, the limits of permissible error may alternatively be identified with the tolerance assigned to the specified value. In this case it must, however, always be checked whether the values of the transmission coefficient determined upon calibration, including their associated uncertainties and their systematic deviations from the specified single value, do not exceed the limits of permissible error.

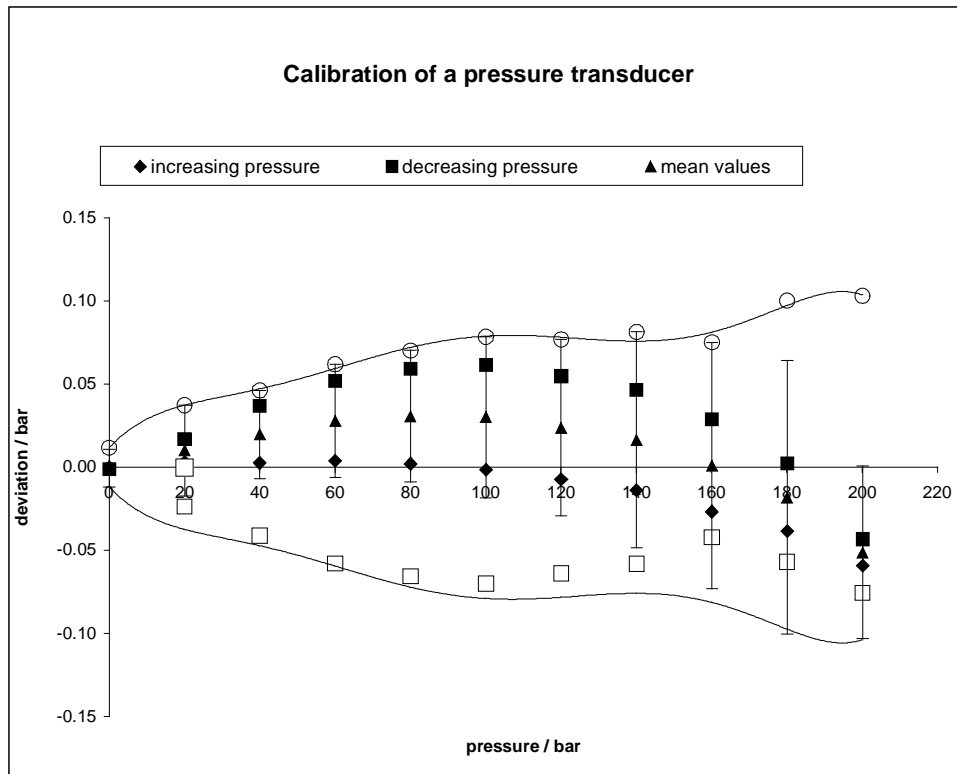

Error bars: Expanded uncertainty of mean values. Solid lines: Error span
Linear characteristic: Measured pressure = 99.9849 bar/(mV/V) Indication
 Open circles: expanded uncertainty estimated as described in example 2a
 Open squares: expanded uncertainty estimated as described in example 2b

Figure 8 Calibration of a pressure transducer

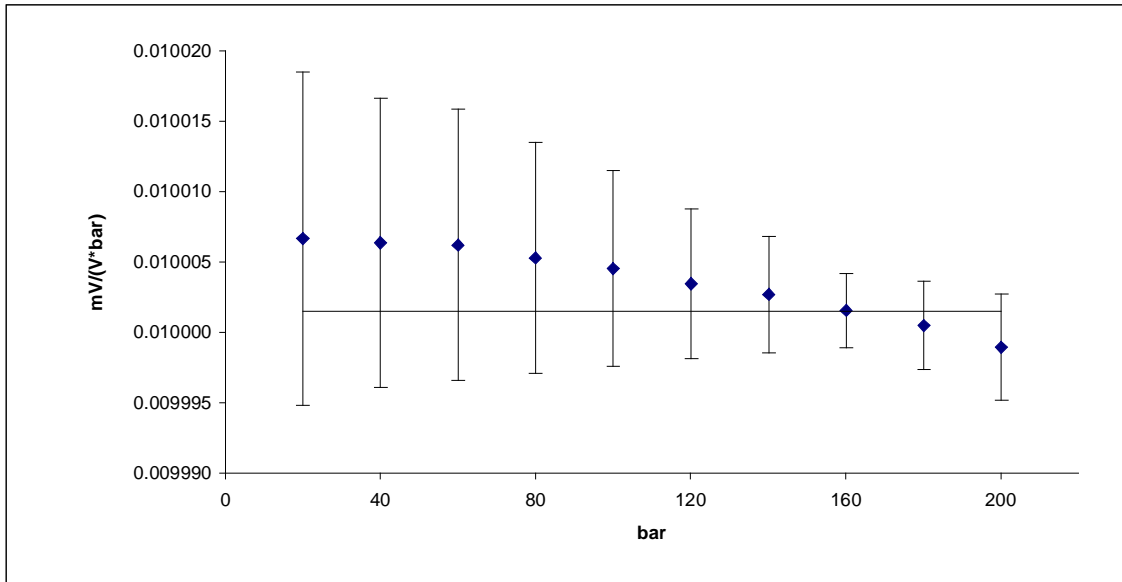

Solid line: Single value

Figure 9 - Transmission factor: Measured values and error spans